

Circuit Switched Fallback Supporting Voice Services in LTE Migration

APPLICATION NOTE 5

The Challenge(s): How to build-out Mobile Broadband Services in the absence of IMS/VoIP.

With VoLTE (Voice over LTE) not yet a realistic solution due to the slow uptake of IMS how can Network Service Providers ensure support for voice in their initial LTE deployments? With voice still a major source of their revenue, this needs to be maintained and offer the same quality of service that their subscribers have become accustomed to.

The move to LTE is complex and time consuming and with the huge demand for high speed data applications many NSPs are focusing on support for data services initially. These initial LTE deployments are happening in urban areas and coverage is not yet ubiquitous, so how do the NSPs ensure subscriber mobility between networks?

At the same time following heavy investment in their existing circuit switched networks the NSPs are looking to preserve CAPEX by extending the life of this equipment. These legacy networks have sufficient capacity to continue to support voice and so why not let them continue to generate revenue?

The Solution: Circuit Switched Fallback (CSFB) addresses this need by providing backward compatibility with circuit-switched services. As specified in 3GPP TS 23.272 (Figure 1) CSFB is the preferred solution for the early stages of LTE deployment. It allows network operators to carry voice traffic over existing GERAN/UTRAN networks from multi-mode LTE UE devices. This very practical goal is realized by a very clever innovation; network awareness in the MME. Where overlapping networks exist, the MME may carry maps of UTRAN TAs (Tracking Areas) to LTE LAs (Location Areas) that allow the UE to utilize CS services all managed from the MME in conjunction with the MSC. When IMS services are unavailable to the LTE network the dual-mode UE is instructed to access the available legacy CS network for voice calls.

CSFB Enhanced VoIP Services: Implementing CSFB does not require changes to the GERAN or UTRAN User Plane services. Existing links and associated transport protocols can be retained if desired, however many MGWs in the field support VoIP. NEPs and NSPs realize that interworking legacy voice to IP at the earliest network entry point possible facilitates the transition to the All-IP network. Voice interworking is being added to the CSFB formula by many forward looking TEMs with the assistance of suppliers like Adax and its partners. (Figure 2).

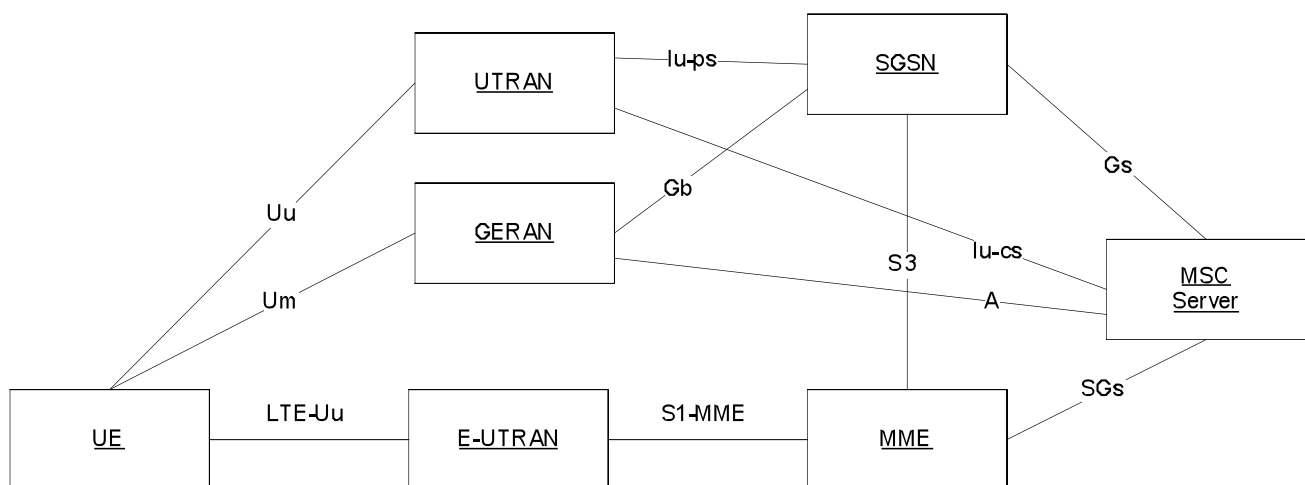

Figure 1: EPS architecture for CS fallback and SMS over SGs from 3GPP TS 23.272 V10.2.1 (2011-04)

The Adax CSFB Gateway Foundation: The CSFB standard explicitly states that no changes are required to the User Plane transport services so there needs to be a way to combine CSFB with the IP EPC (Evolved Packet Core). The solution is User Plane interworking at the Network Edge. This approach brings CS-based voice calls into existing VoIP networks quickly and efficiently. In the UTRAN interworking between ATM-IP is performed on already AMR-encoded voice using RTP (Real-time Transport Protocol) which facilitates multimedia streaming over IP. For truly traditional voice over DS0s, the ATCA I-TDM specification allows T1/E1 and DSP cards to pass traffic seamlessly between them and their associated networks. Most recently Adax, Surf Communication Solutions, and RadiSys delivered such solutions for both GERAN and UTRAN networks providing the platform for a sub-system/OEM/VAS application.

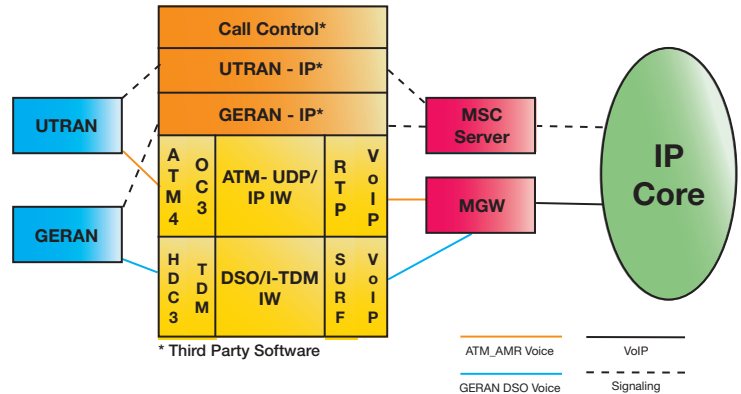

Figure 2: Adax CSFB GW w/VoIP IW Fx

CSFB enables mobile operators to quickly and economically roll out voice services in conjunction with their LTE networks. It allows mobile devices to “fall back” to GSM or UMTS domains for incoming or outgoing voice calls, subscribers maintain access to the wide array of rich circuit-switched capabilities, including international roaming while enjoying LTE broadband access to the Internet.

The CSFB Gateway platform (Figure 2) for existing TDM-based network services uses RadiSys’ carrier-grade ATCA-6006 5U platform, equipped with SBCs and carrier blades, hosting the Adax HDC3 and SURF/Rider AMC cards. Legacy voice and SS7 signaling enter the system on TDM links via the HDC3 T1/E1 ports. Voice channels are interworked to IP using I-TDM and sent to the SURF/Rider card which transmits VoIP packets to the network. Data services are handled by the LTE network or the legacy interface when there is no LTE connection. The 3G solution interworking ATM voice traffic to IP uses the Adax ATM4 card and RTP instead of the Adax HDC3 and SURF/Rider card.

The Adax CSFB Gateway provides the foundation for OEMs, Telecom Equipment Manufacturers and wireless enhancement solution providers to build their CSFB solutions on. For a fully redundant system, cards and blades may be added, removed, and re-allocated with no loss of service. The flexible ATCA architecture fulfils the promise of cost-effective multi-vendor solutions and short time-to-market is achieved through close cooperation between committed ecosystem partners Adax, SURF, and RadiSys.

Benefits:

- Support of voice is a key requirement for LTE networks but Voice over LTE (VoLTE) requires new IMS-specific network elements. CSFB allows Network Service Providers to integrate existing ATM and TDM-based voice and signaling equipment into LTE networks without IMS and the CSFB interworking technologies integrate LTE, 3G and 2.5G networks.
- CSFB extends the field life of legacy equipment into LTE providing Network Service Providers with much needed cost savings as they build out broadband mobile access to the Internet and ATM & TDM-based voice and data services can continue to generate revenues with the minimal CAPEX investment.
- CSFB also sustains user roaming services ensuring that existing subscriber roaming expectations can be met.
- The CSFB Gateway is available as box, or as a blade solution with the Adax PacketRunner, and is quick and simple to install next to or integrated in to the MME, MSC, or Media Gateway ensuring a fast time to market for voice services in the LTE network.
- ATCA flexibility enables the CSFB Gateway to be configured according to individual requirements and the fully redundant architecture provides in-field upgrade capabilities with no loss of service.
- OEMs, Telecom Equipment Manufacturers and wireless enhancement solution providers can quickly and easily add their Call Control applications to the Adax CSFB Gateway Foundation to rapidly deploy their CSFB solution in the Network.

App5 0711/01

About Adax Specializing in Foundations for the All-IP Network, Adax offers a complete set of I/O controllers, blades & signaling gateways for SS7, ATM & IP packet processing, signaling & interworking. Adax high performance products meet today’s challenges of I/O scalability, cost effectiveness and high availability in LTE, NGMN and IMS networks.