

ATM4 – ATM to IP Interworking Controller



ATM - IP Overview

The ATM4-AMC card is a high performance AdvancedTCA Mezzanine Controller designed for use in all aspects of telecommunications networks. The ATM4 includes support for ATM host termination, switching and L2/L3/L4 or higher interworking between Gigabit Ethernet interfaces and ATM interfaces. With support for AAL2 and AAL5, the ATM4 has the ability for real-time voice and video over AAL2, as well as signaling and IP over AAL5 in 3G networks. The ATM4 is ideal for demanding carrier applications in Wireless 2G, 3G, IMS, Internet Access, Fixed/Mobile Convergence and Next Generation Networks such as:

- 3G RNC, MSC, SGSN, and Node B
- Voice over Packet
- Video Streaming
- Broadband Networks
- ATM to IP Gateways
- Femtocell Access Controller

The ATM4 enables development flexibility in building Next Generation infrastructure and can be configured in many ways depending on customer specifications and preferred architecture. In addition, the AMC form factor provides enhanced performance and reliability.

One or two ATM4's, integrated with an ATCA/SBC, can be configured as a signaling blade, housing complete ATM/IP gateways and offering a high density, single slot, market leading solution. Alternatively, up to four AMC modules can be mounted with an Advanced TCA carrier card for a high density ATCA signaling blade. This flexibility enables integrators to satisfy a wide range of requirements with a single core architecture, saving development time and allowing customers to integrate their solutions ahead of the competition.

ATM4 Features

- Multi-Purpose I/O board for 3GPP/IMS Wireless Networks
- AMC form factor for ATCA & MicroTCA Platforms
- On-board IP to AAL2 & IP to AAL5 Interworking
- ATM AAL2 & AAL5 on a single trunk
- 2048 Virtual Circuits (VCs) for AAL5 termination
- Up to 64000 VC for AAL2 switching at full rate between ports
- Four OC-3/STM-1 or Two OC-12/STM-4
- APS for 1:1, 1+1, 1+n ports
- External clock synchronization
- IPMI subsystem provides ATCA/AMC.0 hot swap and board management services
- Transparent field upgrades, without host rebooting, saving downtime
- Multiple cards per system providing highly flexible and completely scalable solutions
- State of the art Wintegra WinPath2 Network Processor
- Utopia L2, Gigabit Ethernet & PCIe Bus to Carrier
- User-configurable support for Frame/MSU Time-Stamping
- On-board switching
- SFP Optical Transceivers
- Backwardly compatible APIs to Adax ATMII and ATMIII products
- SAAL software; SSCOP, SSCF/SSCS and SSSAR/SSTED/ SSADT
- Comprehensive alarms and status reporting capabilities
- Software drivers for Linux and Solaris as standard. Other OS support on request

ATM

- AAL2 & AAL5
- ATM cell switching
- AAL2 CID switching
- Traffic management as per TM 4.1: CBR, VBR, GFR and UBR
- Per VC queuing
- Dual leaky bucket policing
- Full UNI/NNI VPI/VCI range
- OAM F4 and F5 as per ITU-TI.610

Interworking

- IP routing and forwarding over ATM (RFC 1483/2684/1577)
- IP routing and forwarding over PPP (RFC 1661)
- Multiple fields classification and Diffserv (RFC 2474/2475)
- MPLS tagging/detagging
- L2 interworking between ATM and Ethernet
- Header compression (RFC 2507/2508/2509)
- AAL2 to UDP/IP interworking (CPS and SSSAR)
- AAL5 to UDP/IP interworking
- GTP-U UDP/IP (3GPP Standard 29.060)

IP

- IPv4 and IPv6
- PPP support
- HDLC support up to OC-3 rates
- Parsing of PPP over HDLC frames (RFC 2615 and RFC 1662)
- Packet Scheduling
- Diffserv (RFC 2474/2475)

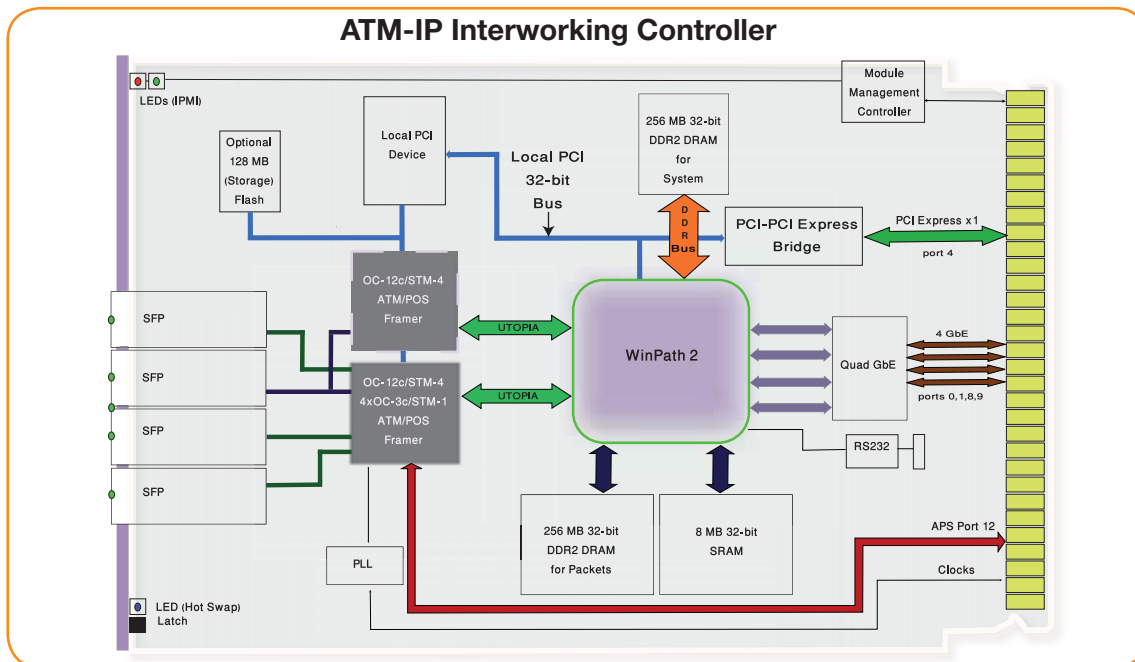

Application Overview

The ATM4 is the ideal solution for wireless networks because it accommodates different types of system architectures depending on customer requirements. The flexibility of the ATM4 results in a high performance, cost-effective solution that reduces time to market by minimizing customer development time and costs.

The ATM4 offers several different architecture options. Up to four ATM4 modules can be mounted on a carrier card with communication across the bus interface to the CPU or other AMC cards. Alternatively, they can be combined with an AMC/SBC to create a self contained signaling blade in service of the main application. Ultimately, the ATM4 can be configured as a broadband signaling solution on a card.

The ATM4 can be implemented throughout UMTS/3G network nodes, offering unparalleled flexibility for building SGSNs, MSCs, RNCs, Node-Bs, and making it the ideal solution for developers building crucial 3G infrastructure.

Serving GPRS Support Nodes (SGSN) and Mobile Switching Centers (MSC)

The ATM4 can sit beneath all the signaling protocol stacks in the SGSN and MSC in a UMTS network, with support for a variety of protocols simultaneously on the card. The Radio Access Network Application Part is the Radio Access Layer for the lu interface and is found in both the SGSN and MSC. Here, integration is at the MTP3b and M3UA level via SSCOP/SSCF and SCTP respectively. SSCOP/SSCF runs over AAL5 on the Adax ATM card. The GPRS Tunneling Protocol (GTP) in the SGSN runs IP over Ethernet, and AAL5 over ATM using Adax Frame Relay. GTP is supported by the Ga, Gn and Gp interfaces, which interconnect the SGSN to the GGSN and charging gateways.

Radio Network Controllers (RNC)

The ATM4 supports both the lu-PS and lu-CS interfaces for which RANAP is the Radio Network Layer signaling protocol. As described above, Adax can fully support the RANAP stack using AAL5. In addition, the lu-CS requires AAL2 transport, and the ATM4 can support the passing of AAL2 multiplexed traffic. The ATM4-AMC provides the ideal solution for any customer requiring 3G signaling.

Node-B

With support for AAL2, AAL5 and interworking between AAL2/5 and UDP/IP, the ATM4 provides high performance signaling and data transfer for the Node-B in UMTS networks. The Adax SSCOP/SSCF/AAL5 links transfer the control plane traffic, while the AAL2 subchannel with interworking feature transfers and routes the real time user plane traffic. Consequently, the ATM4 can be deployed within every UMTS network node, from the edge of the Radio Network Subsystem right through into the heart of the Core Network.

Signaling Blade

Multiple ATM4 modules can be mounted onto an ATCA SBC and together with the AdaxGW software can be configured as a complete Signaling Gateway resulting in a powerful, high-density single slot solution for SS7, SIGTRAN or SS7/IP signaling. The SIGTRAN protocols over Ethernet ports provide the SS7 transport over IP and this enables the simple and straightforward integration of existing SS7 Intelligent Nodes and databases with IP-based Media Gateways and Softswitches. With the ability to run a complete signaling stack or gateway on one card, the signaling blade enables an extremely cost-effective solution supporting OC3/STM-1 interfaces and, when used in conjunction with the Adax HDC3-AMC, T1/E1/J1 interfaces.

Ease of Installation and Application Development

Adax pride themselves on the consistency of their programming interface, which offers true backwards compatibility and the ability to port applications between operating systems without any change. The single software driver for all formats ensures that Adax cards can be running in hours, rather than weeks, and with the supplied testing applications users can be writing their own applications immediately. Adax cards not only provide fast time to market, they also reduce the huge initial development costs that are associated with projects and lower the overall cost of ownership.

ATM4C* – Channelized OC3/STM-1

In addition to the ATM4 ATM to IP interworking card, Adax has also designed a Channelized AMC board. The ATM4C supports protocol interworking between any of its 4 OC3/STM-1 as well as 2-4 GbE to the backplane. It is ideal for demanding carrier applications in WiMAX, CDMA, Internet Access, Fixed/Mobile Convergence and Next Generation Networks such as:

- Wireless Radio Network Controllers
- Base Station Controllers
- High Performance Routers
- Media Gateways
- Voice over Packet Gateways
- Voice Service Platforms
- Video Streaming
- Broadband Networks
- ATM to IP Gateways

The ATM4C card offers extensive protocols for various applications requiring Channelized DS1, DSO I-TDM, ATM, HDLC, MLPPP and IP support. This Next Gen Channelized AMC offers flexibility in building Next Generation infrastructure and can be configured in many ways depending on customer specifications and preferred architecture.

ATM4C Features

- Multi-Purpose Channelized board
- APS for 1+1, 1:1 and 1:N support on all OC3 STM-1 ports using AMC port 12
- Quad Channelized OC-3 to DS1 level (up to 336 DS1/252 E1)
- Quad Channelized OC-3 to DSO level (up to 8064 HDLC channels)
- TDM based on SFP.0 for DS1 processing over Gigabit Ethernet ATCA backplane
- PCI Express to host and Gigabit Ethernet to ATCA backplane
- Clock Synchronization
- IPMI subsystem provides ATCA/AMC.0 hot swap and board management services
- User-configurable support for Frame/MSU Time-Stamping
- Transparent field upgrades, without host rebooting, saving downtime

Complete Scalability

Adax customers benefit from unparalleled flexibility of a product set that delivers a range of diverse and extensive Protocol Controllers, Signaling Software and Signaling Gateways, with the complete scalability that enables Adax to accommodate the smallest to largest requirement. Adax customers can deploy their signaling applications, nodes or systems as quickly and efficiently as possible, irrespective of the underlying network interface or architecture, because Adax provides Foundations for Converging Networks.

- Multiple cards per system providing highly flexible and completely scalable solutions
- State of the Art Wintegra WinPath2 Network Processor
- On board UFE3 Control Processor
- Comprehensive alarms and status reporting capabilities
- Software drivers for Linux and Solaris as standard. Other OS support on request

ATM

- AAL2 & AAL5 termination & switching
- ATM cell switching & AAL2 CID switching
- IMA support for ATM
- Traffic management as per TM 4.1: CBR, VBR, GFR and UBR
- Per VC queuing
- Dual leaky bucket policing
- Full UNI/NNI VPI/VCI range
- OAM F4 and F5 as per ITU-TI.610

Interworking & Termination

- Layer 2 termination & interworking for various switching and routing applications
- HDLC encapsulation to Gigabit Ethernet
- MLPPP interworking to Gigabit Ethernet
- IP routing and forwarding over ATM (RFC 1483/2684/1577)
- IP routing and forwarding over PPP (RFC 1661)
- Multiple fields classification and DiffServ (RFC 2474/2475)
- MPLS tagging/detagging
- Header compression (RFC 2507/2508/2509: future release)
- AAL2 to UDP/IP interworking (CPS and SSSAR)
- TDM to iTDM interworking
- AAL5 to UDP/IP interworking

IP

- IPv4 and IPv6
- MLPPP/PPP support
- HDLC support up to 8064 DSO
- Parsing of PPP over HDLC frames (RFC 2615 and RFC 1662)
- Packet scheduling

* Future Release

Technical Specifications – ATM4

Protocol Support

- ATM AAL2, ITU-T I.363.2
- ATM AAL5, ITU-T I.363.5
- SSCOP, Q.2110
- SSCF NNI, Q2140
- SSCF at UNI per Q.2130
- SSCS Layer Management Q.2144
- SSSAR/SSTED/SSADT, ITU-T I.366.1
- HSL over AAL5, Telcordia GR-2878-Core

AMC System Interconnect

- PCI Express One x1 Express Interface
- Gigabit Ethernet Four Gigabit Ethernet links on AMC ports 0-1 and 8-9

Front Panel LEDs

- AMC.0 IPMI (2x)
- Hot Swap (Adjacent to Latch)
- Per Port Status (4x)
- Board Status/User Programmable

Interfaces

- Four OC-3/STM-1
- Two OC-12/STM-4
- Support for single mode fiber and multi-mode fiber (ITU G.957)

ATM/POS

- STM-1 / STS-3c
- STM-4 / STS-12c
- ATM (ITU I.432)
- POS (RFC 1619 / RFC 1662)

Telecom Clock

- 8 kHz to 19.44 MHz PLL
- Meets TR62411, ETS300.011 and GR – 1244 for Jitter/Wander for Stratum 3 and higher
- 8 kHz selectable from backplane or any STM-1/STS-3c port
- 8 kHz reference output to backplane
- Locks to +/- 100 ppm

Optical Transceivers

- Multisource agreement (MSA) compliant SFP package
- LC duplex receptacle connector
- Hot pluggable electrical interface
- One AMC card for all variants: Multimode, single mode, short, intermediate and long reach

Power Requirements

- 24 Watts max

Compliance

- PICMG AMC.0 Specification R2.0
- PICMG AMC.1 PCI Express Advanced Switching R1.0
- PICMG AMC.2 Gigabit Ethernet R1.x
- IPMI V1.5 Intelligent Platform Management Interface Specifications

Designed to meet:

- EMC Directive 89/336/EEC, EN 55022, EN55024 (Europe)
- Conforms to EN60950 for safety
- EN 300 386
- FCC 47 CFR Part 15, Subpart B (USA)
- CISPR22
- VCCI (Voluntary Japan Electromagnetic Compatibility requirement)
- UL 60950-1, First Edition (US and Canada)
- LVD 73/23EEC (Europe)
- Denen Law (Japan Safety)

Temperature Range

- -5 °C +55 °C ambient

Board Dimensions

- AMC Mid size -181.5 mm x 73.5 mm

Technical Specifications – ATM4C

Protocol Support

- ATM AAL2, ITU-T I.363.2
- ATM AAL5, ITU-T I.363.5
- MLPPP
- HDLC
- SSCOP, Q.2110
- SSCF NNI, Q2140
- SSCF at UNI per Q.2130
- SSSAR/SSTED/SSADT, ITU-T I.366.1
- SSCS Layer Management Q.2144

AMC System Interconnect

- PCI Express One x1 Express Interface
- Gigabit Ethernet Four Gigabit Ethernet links on AMC ports 0-1 and 8-9

Front Panel LEDs

- AMC.0 IPMI (2x)
- Hot Swap (Adjacent to Latch)
- Per Port Status (4x)
- Board Status/User Programmable

Interfaces

- Four OC-3/STM-1
- Support for single mode fiber and multi-mode fiber (ITU G.957)

ATM/POS

- ATM (ITU I.432)
- POS (RFC 1619 / RFC 1662)

Telecom Clock

- 8 kHz to 19.44 MHz PLL
- Meets TR62411, ETS300.011 and GR – 1244 for Jitter/Wander for Stratum 3 and higher
- 8 kHz selectable from backplane or any STM-1 port
- Locks to +/- 100 ppm

Optical Transceivers

- Multisource agreement (MSA) compliant SFP package
- LC duplex receptacle connector
- Hot pluggable electrical interface
- One AMC card for all variants: Multimode, single mode, short, intermediate and long reach

Power Requirements

- 24 Watts max

Compliance

- PICMG AMC.0 Specification R2.0
- PICMG AMC.1 PCI Express Advanced Switching R1.0
- PICMG AMC.2 Gigabit Ethernet R1.x
- IPMI V1.5 Intelligent Platform Management Interface Specifications

Designed to meet:

- EMC Directive 89/336/EEC, EN 55022, EN55024 (Europe)
- Conforms to EN60950 for safety
- EN 300 386
- FCC 47 CFR Part 15, Subpart B (USA)
- CISPR22
- VCCI (Voluntary Japan Electromagnetic Compatibility requirement)
- UL 60950-1, First Edition (US and Canada)
- LVD 73/23EEC (Europe)
- Denen Law (Japan Safety)

Temperature Range

- -5 °C +55 °C ambient

Board Dimensions

- AMC Mid size -181.5 mm x 73.5 mm

All specifications are subject to change without notice.

ATM4C 1208/10

About Adax Specializing in *Foundations for Converging Networks*, Adax offers a complete set of protocol controllers, integrated software and signaling gateways. Adax high performance products are available for SS7, ATM and IP protocols for PSTN, GPRS, 3G and IMS networks.



adax inc
614 Bancroft Way, Berkeley,
CA 94710, USA
Tel: (510) 548 7047 Fax: (510) 548 5526
Email: sales@adax.com Web: www.adax.com

adax europe ltd
Reada Court, Vachel Road,
Reading, Berkshire, RG1 1NY, UK
Tel: +44 (0) 118 952 2800 Fax: +44 (0) 118 957 1530
Email: sales@adax.co.uk Web: www.adax.com

adax china
Room 1107, Building A
No. 527 Center Huaihai Road
Shanghai 200020, China
Tel/Fax: (86 21)5351 0279
Email: sales@adax.com Web: www.adax.com